



## SAY YES TO SOLAR POWER!

Because it protects the climate.

### Innovation from the photovoltaic pioneer

Sharp, as a solar specialist with 50 years of experience in photovoltaics (PV), makes an essential contribution towards groundbreaking advancements in solar technology.

The NT Sharp series of photovoltaic modules is designed for applications with a high power requirement.

These monocrystalline quality modules produce a sustained, reliable yield even under demanding deployment conditions.

All Sharp NT series modules offer optimal system integration – both technically and economically – and are suitable for installation in grid-coupled systems.

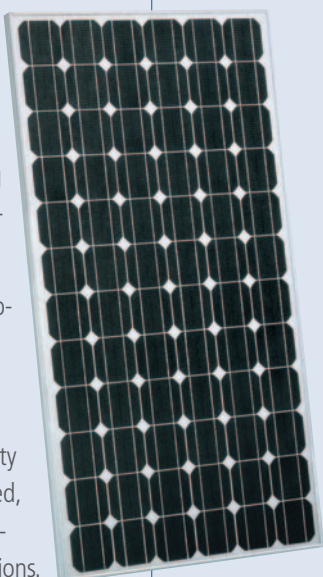

### Brief information for the installer

- 125.5 mm x 125.5 mm monocrystalline solar cells
- 72 cells in series
- 2,400 N/m<sup>2</sup> mechanical load-bearing capacity (245 kg/m<sup>2</sup>)
- 1,000V DC maximum system voltage
- CE tested for your safety

### Product features

- High performance photovoltaic modules made of monocrystalline (125.5 mm)<sup>2</sup> silicon solar cells with module efficiency of up to 13.5 %.
- Bypass diodes to minimise power loss with shading.
- Textured cell surface for especially high current yields.
- BSF structure (Black Surface Field) for optimising cell efficiency.
- Use of annealed glass, EVA plastic and weather-protection foil, as well as an anodised aluminium frame with water drainage holes for prolonged use.
- Output: connection cable with water-protected plug connector.

### Quality from Sharp

Sharp Solar quality sets standards. Permanent monitoring guarantees consistent high quality. Each module is optically, mechanically and electrically tested. You recognise it from the original Sharp label, the serial number and the Sharp guarantee:

- 2 year product guarantee
- 10 year performance guarantee for a 90 % power output
- min. 20 year performance guarantee for a 80 % power output

The detailed guarantee conditions and further information are available at [www.sharp-world.com](http://www.sharp-world.com).

Mechanical data	
Cell	Monocrystalline (125.5 mm) <sup>2</sup> Sharp silicon solar cells
Number and connection of cells	72 in series
Dimensions	1,575 x 826 x 46 mm (1.30 m <sup>2</sup> )
Weight	17 kg
Connection type	Cable with plug connector (MC-3)

Limit values		
Storage humidity	up to 90	%
Operating temperature (cell)	-40 to +90	°C
Storage temperature	-40 to +90	°C
Maximum system voltage	1,000	V DC
Maximum mechanical load	2,400	N/m <sup>2</sup>

Electrical data			
Module production in the EU		NT-175 (E1)	NT-170 (E1)
Module production in Japan		NT-R5 (E3E)	NT-R0 (E3E)
Rated power		175 W <sub>p</sub>	170 W <sub>p</sub>
Open circuit voltage	V <sub>OC</sub>	44.4	44.2
Short circuit current	I <sub>SC</sub>	5.40	5.30
Voltage at maximum power	V <sub>PM</sub>	35.4	35.0
Current at maximum power	I <sub>PM</sub>	4.95	4.86
Module efficiency	η <sub>m</sub>	13.5	13.1
Temperature coefficient – open circuit voltage	αV <sub>OC</sub>	-156	-156
Temperature coefficient – short circuit current	αI <sub>SC</sub>	+0.053	+0.053
Temperature coefficient – power	αP <sub>M</sub>	-0.485	-0.485

The electrical data applies under standard testing conditions (STC): Radiation 1,000 W/m<sup>2</sup> with a spectrum of AM 1.5 and at a cell temperature of 25 °C. The power output is subject to a manufacturing tolerance of von - 5 % and + 10 %. The modules manufactured in Europe and Japan are identical.

## Characteristic curves

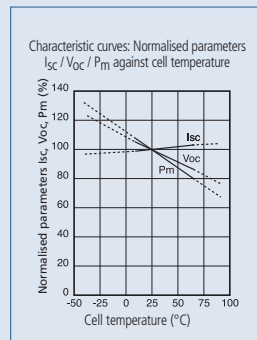
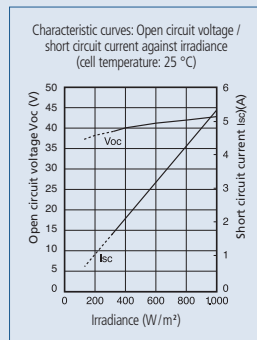
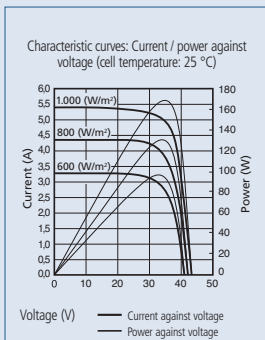

## Applications

- On-grid PV systems
  - Off-grid systems
  - On-roof PV systems (roof parallel)
  - On-roof PV systems (on stilts)
  - Ground installations
- Please read our extensive installation guide carefully prior to installing the photovoltaic modules.

## External dimensions

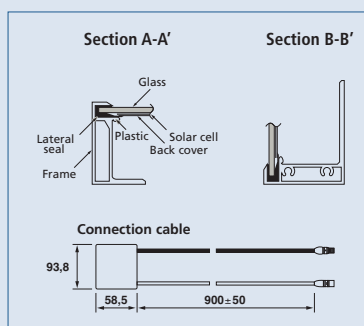
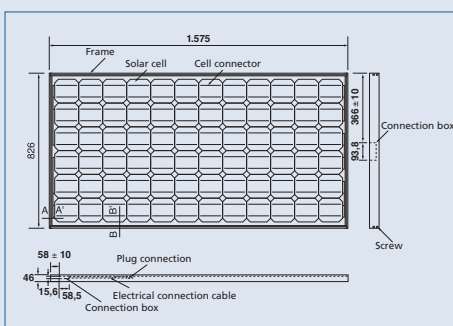

## Note

Modifications to technical data are possible without prior notice. Please request the current data sheets from Sharp before using Sharp products. Sharp assumes no responsibility for damage caused to equipment fitted with Sharp products based on unverified information.

The specifications may deviate slightly and are not guaranteed. Installation and operating instructions are to be obtained from the relevant manuals or can be downloaded from [www.sharp-world.com](http://www.sharp-world.com).

This module should not be connected directly to a load.



**Central & Eastern Europe**  
Tel: +43-(0)1-72 71 90 · Fax: +43-(0)1-72 71 91 41  
[www.sharp-cee.com](http://www.sharp-cee.com)

**France**  
Tel: +33-(0)1-49 90 34 00 · Fax: +33-(0)1-48 63 26 21  
[www.sharp.fr](http://www.sharp.fr)

**Germany & Austria**  
Tel. Germany: +49-(0)18 05-01 52 22 (0,12 €/min.)  
Tel. Austria: +49-(0)8 20-40 06 40 (0,145 €/min.)  
[www.sharp.de/solar](http://www.sharp.de/solar) | [www.sharp.at/solar](http://www.sharp.at/solar)

**Italy**  
Tel: +39-02-89 59 51 · Fax: +39-02-89 53 08 95  
[www.sharp.it](http://www.sharp.it)

**Spain & Portugal**  
Tel: +34-(0)93-5 81 97 00 · Fax: +34-(0)93-6 75 46 11  
[www.sharp.es](http://www.sharp.es)

**Nordic Countries**  
Tel: +46-(0)8-6 34 36 00 · Fax: +46-(0)8-6 34 36 10  
[www.sharp.se](http://www.sharp.se)

**Switzerland**  
Tel: +41-(0)1-8 46 61 11 · Fax: +41-(0)1-8 46 62 25  
[www.sharp.ch](http://www.sharp.ch)

**Benelux**  
Tel: +31-(0)30-6 35 95 00 · Fax: +31-(0)30-6 35 95 95  
[www.sharp.nl](http://www.sharp.nl) | [www.sharp.be](http://www.sharp.be)

**United Kingdom**  
Tel: +44-(0)1 61-2 05 23 33 · Fax: +44-(0)1 61-2 05 70 76  
[www.sharp.co.uk/solar](http://www.sharp.co.uk/solar)